



Solid State Timers and Controllers

0.1 Seconds to
1024 Hours!

2311SA

DIP Switch Adjustable
Re-triggerable Single Shot



The 2311SA is a re-triggerable single shot timer controlling a SPDT set of relay contacts. It is available in both AC and DC voltage models, and all models provide an integral 12 position DIP switch used to determine the time delay value. With the operating voltage applied the unit is in standby mode. Closure of the Initiate Switch transfers the output contacts and begins the time delay, at the end of which the output contacts de-energize. Opening and reclosing the switch before the end of the delay resets the timing period. Removal of input power during the timing period will de-energize the output contacts. DIP switches 11 & 12 determine the time delay range, while switches 1 - 10 determine the time delay period. The integral LED indicates the state of the output contacts.

Timing Diagram

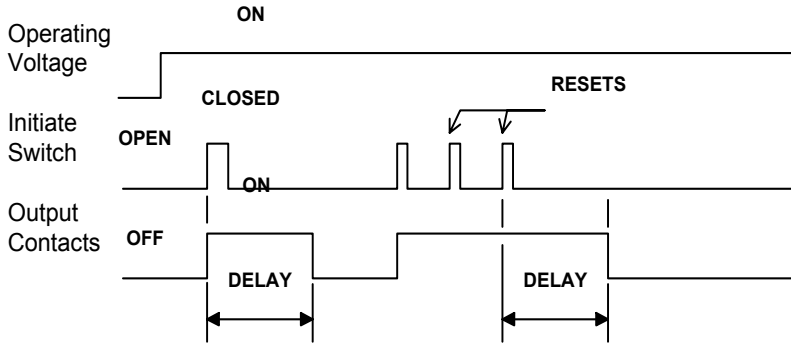
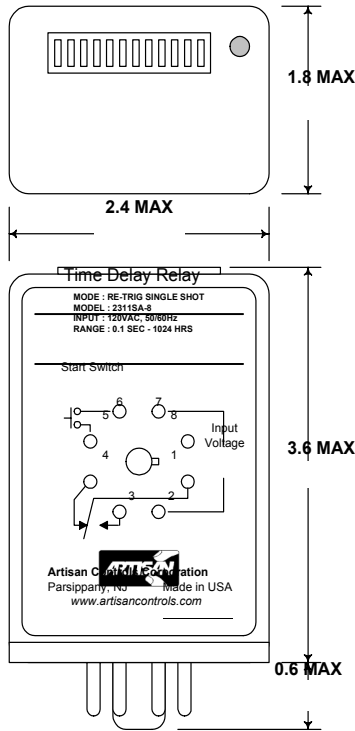

Setting the Time Delay

Setting the time delay is an easy two step process :

Selecting the Time Range - Open or Close switches 11 & 12 per the chart below to select from the four time ranges: 0.1 - 102.4 seconds, 1 - 1024 seconds, 1 - 1024 minutes, and 1 - 1024 hours.

Setting the Time Delay - The timer has a built-in delay equal to the switch 1 value for the selected range (0.1 sec, 1 sec, etc.). Close the additional switches (1 - 10) which add their values from the chart below to the built-in time to achieve the desired time delay.

Example: To set for 30 minutes - switches 11 closed and 12 open for minutes range, then close switches 5, 4, 3, and 1 for a total of 29 minutes, all other switches open. The built in 1 minute completes the full 30 minutes.

DIP Switch Chart

1	2	3	4	5	6	7	8	9	10	11	12	Time Delay Range
0.1	0.2	0.4	0.8	1.6	3.2	6.4	12.8	25.6	51.2	off	off	0.1 - 102.4 Seconds
1	2	4	8	16	32	64	128	256	512	off	ON	1 - 1024 Seconds
1	2	4	8	16	32	64	128	256	512	ON	off	1 - 1024 Minutes
1	2	4	8	16	32	64	128	256	512	ON	ON	1 - 1024 Hours

Notice: Artisan Controls Corporation assumes no responsibility for customer's applications or product design. The information and data contained herein is the sole and exclusive property of Artisan Controls Corporation. Any duplication, misuse, or conversion of this information without the express written consent of Artisan Controls Corporation is illegal and will result in damages including court costs and attorney fees being assessed against the party misusing this property.



Solid State Timers and Controllers

Specifications

- Timing Mode:** Microprocessor-based retriggerable Single Shot.
- Operating Voltage:** Nonpolarized connection, see values below, 50/60 Hz for AC voltages.
- Operating Power:** Idle operating current < 10mA for all voltages. Nominal operating current with relay output energized is 60mA @ 12VDC (-2), 30mA @ 24V AC/DC (-3), 15mA @ 115VAC (-8).
- Operating Voltage Tolerance:** -10%/+20%
- Operating Temperature:** -20°C to +65°C.
- Purchase Tolerance:** ±2% or 20mS whichever is greater.
- Timing Repeatability:** Better than ±2%.
- Time/Temperature Coefficient:** Better than ±0.1%/°C.
- Recycle Time:** 75mSec minimum with relay on, 150mSec minimum with relay off.
- Output Relay Ratings:** SPDT contacts rated 12A resistive at 125VAC, 7A resistive at 250VAC/30VDC.
- Contact Life Expectancy:** 30,000 cycles @ 12A/120VAC, 100,000 cycles @ 10A/120VAC or 7A/240AC, 900 cycles/hour maximum w/resistive load.
- Terminations:** Octal plug-in type.
- Dielectric Rating:** 750 Vrms between open contact sets, 1500 Vrms between contacts and operating voltage terminals.
- Transient Protection:** Protected by silicon transient suppressors responding to transients within 1×10^{-12} seconds to a peak pulse power dissipation of 1500W.
- Agency Recognition:** Certified to UL Component-Appliance Controls ATNZ2 (US) and ATNZ8 (Can), UL File E47858.

Document © and Revision Date: June 21, 2006

Ordering Information

Model Number	Operating Voltage
2311SA	-2 (12V DC)
	-3 (24V AC/DC)
	-8 (120V AC)

48V and 230V units available on special order

Typical Wiring Example

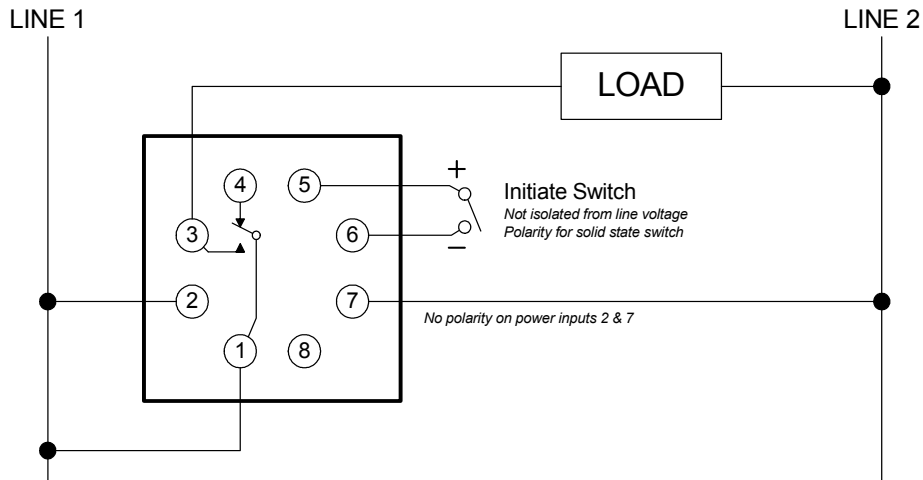

Notice: Artisan Controls Corporation assumes no responsibility for customer's applications or product design. The information and data contained herein is the sole and exclusive property of Artisan Controls Corporation. Any duplication, misuse, or conversion of this information without the express written consent of Artisan Controls Corporation is illegal and will result in damages including court costs and attorney fees being assessed against the party misusing this property.